

# Unconscious vs. Conscious Thought in Causal Decision Making

Stefan Mangold (smangol@uni-goettingen.de)

York Hagmayer (yhagmay@uni-goettingen.de)

Department of Psychology, University of Göttingen, Gosslerstr. 14, 37073 Göttingen, Germany

## Abstract

Recently, Unconscious Thought Theory (UTT, Dijksterhuis & Nordgren, 2006) claimed that unconscious processing of information yields better decisions. Related studies showed that deliberate reasoning resulted in worse choices than unconscious reasoning. Causal reasoning is often considered to be a form of deliberate, rule-based reasoning (Sloman, 1996) and causal decision making is assumed to involve inferring the potential consequences of different actions from mental causal models (Sloman & Hagmayer, 2006). Therefore, better choices would be expected after deliberation. Two experiments investigated causal decision making using the UTT paradigm. It turned out that more effective actions were chosen, when participants were asked to deliberate rather than to turn their attention to another task or to decide immediately. These results add to other findings indicating that the superiority of unconscious thought may be limited to specific decision making situations.

**Keywords:** Causal reasoning; unconscious thought theory, decision making

## Introduction

When receiving a diagnosis of cancer a difficult period with many important decisions lies ahead for many patients. One important decision is which of the available treatment options should be pursued. Each option (e.g., chemotherapy, radiation therapy, endocrine therapy) has many pros and cons and entails substantial consequences for the patient's wellbeing and survival. Until very recently the recommendation would have been to resort to deliberate decision making given such a complex problem. Now there is increasing evidence suggesting that it may be better not to consciously work on a problem, but to distract oneself for some time and then make a choice without any further thought. For example, in a study conducted by Dijksterhuis, Bos, Nordgren, and van Baaren (2006), participants were more likely to choose the best out of four cars (i.e., the car having the highest number of positive attributes) after a period of distraction than after a period of deliberate thought. These findings led to the development of Unconscious Thought Theory (UTT, Dijksterhuis & Nordgren, 2006).

## Unconscious Thought in Decision Making

Unconscious thought theory assumes that unconscious processes, which continue to work on a problem while the conscious attention is directed somewhere else, are better suited to adequately weight and integrate the given information than conscious deliberation. According to UTT there are several more specific reasons for the inferior decision performance after a period of conscious deliberation. First,

the capacity of conscious working memory is restricted in terms of limited storage and sequential processing. Unconscious processing is assumed to have no such restrictions (cf. Evans, 2008). Second, while conscious thought is guided by expectancies, rules and schemas, which lead to increased stereotyping and biased representations of the information given, unconscious thought “slowly integrates information to form an objective summary judgment” (Dijksterhuis & Nordgren, 2006, p. 98). A third advantage of unconscious thought is its ability to automatically weight different attributes according to their relative importance. Conscious thinking is assumed to disturb this process because it “leads people to put disproportionate weight on attributes that are accessible, plausible, and easy to verbalize” (ibid., p. 100).

Decisions based on unconscious thought are also assumed to be better than decisions made immediately after receiving all relevant information. During information acquisition a mental representation of the object at hand is formed. While this representation is the only basis for decisions made immediately, the representation is actively changed during unconscious thought resulting in an improved performance (see Dijksterhuis, 2004; Strick, Dijksterhuis, & van Baaren, 2010 for more details).

Predictions of UTT have been supported by numerous studies on a variety of choice topics (e.g. Dijksterhuis et al., 2006; Lerouge, 2009). However, there are also some contradictory findings (e.g., Newell, Wong, Cheung, & Rakov, 2009). One interesting finding by Payne, Samper, Bettman, and Luce (2008) was that deliberate thought turned out to be as successful as unconscious thought when decision makers could determine the time for deliberation themselves. These findings indicate that unconscious thought may not be generally better than deliberation.

## Causal Reasoning in Decision Making

Many important decisions concern interventions into causal systems, for example, medical treatments to improve health or political interventions to stimulate economic growth. Sloman and Hagmayer (2006) have argued that people tend to construct mental *causal models* when a decision is made with respect to a causal system. First, a causal model of the choice situation is constructed that represents the causal mechanisms relating options (i.e., available courses of action), outcomes, and payoffs. Second, possible interventions are implemented in the model and consequences are predicted by mental simulation. Finally, the option resulting in the best overall outcome is chosen. The crucial advantage of causal reasoning in decision making is that it allows envi-

sioning the consequences of actions never taken or observed before (cf. Hagmayer et al., 2010).

In a number of studies Hagmayer and Sloman (2009) demonstrated that peoples' decisions are contingent on their causal beliefs when making simple one-shot decisions in hypothetical scenarios. The studies also showed that people spontaneously activate causal beliefs before making a choice. Similar findings are reported by research on naturalistic decision making (Klein, 1998). When experts are not familiar with a particular problem, they tend to simulate potential courses of action to figure out whether they would allow to achieve the desired outcome.

Causal reasoning is a form of rule-based reasoning and is therefore usually considered to be a form of analytic, deliberate, System 2 reasoning (Sloman, 1996). If this assumption is correct, then causal decision making relies on deliberate thought. Therefore decisions should be best when based on deliberations.

## Goals and Hypotheses

Studies on unconscious thought in decision making tend to focus on consumer choice tasks, in which participants have to choose between options characterized by various attributes. It is manipulated whether participants have to make their decision immediately after receiving all relevant information (immediate choice condition), after working on an attention grabbing task for a specified amount of time (unconscious thought condition), or after deliberating for the same amount of time (conscious thought condition). By contrast, studies on causal decision making usually ask participants to choose between actions having a differential impact on a causal system. There are no restrictions with respect to the processing of the given information and decision making. Although this lack of restrictions could be assumed to facilitate deliberate thinking, the studies provide no empirical evidence for this hunch. On the other hand, studies on unconscious thought have not investigated decision making with respect to causal systems. Thus they provide no evidence on causal decision making.

The main goal of the present set of experiments is to close this gap in knowledge by investigating unconscious thought in causal decision making. Therefore we combined the unconscious thought paradigm with a task asking participants to rate the causal consequences of different options (Experiment 1) or to choose between interventions (Experiment 2). Based on causal model theories of reasoning and decision making (Sloman, 1996, 2005, Sloman & Hagmayer, 2006) we hypothesized that time for conscious deliberation would improve the decisions made. Thus we expected more choices of the most effective intervention or the option having the best causal consequences after deliberation than after unconscious thought or when the decision had to be made immediately. Note that we do not predict that participants would be unable to make an appropriate decision if they had no extra time for deliberation. While acquiring the information to make a decision, persons may already engage in some form of reasoning.

## Experiment 1

The goal of this first experiment was to investigate how different processing conditions affect decision making when the structure of a causal system needs to be considered to find the best option. The processing conditions were adapted from Dijksterhuis et al. (2004) and Payne et al. (2008) and required a decision either (i) immediately, (ii) after unconscious thought while being distracted, (iii) after conscious deliberations for a fixed time interval, or (iv) after self-paced conscious deliberations.

### Method

**Participants and Design** 104 Göttingen university undergraduates participated for course credit or were paid €7. They were randomly assigned to one of the four processing conditions (Immediate, unconscious thought, conscious thought, and conscious thought self-paced).

**Materials and Procedure** Experiment 1 consisted of three phases: A familiarization phase, an instruction phase, and a test phase. During the first phase participants were familiarized with their respective processing condition to ensure that they could focus entirely on the task during the test phase. First, all participants had to practice to rate objects within 3 seconds by clicking on one of the buttons forming a 11-point rating scale. The time constraint was introduced in order to prevent conscious deliberation during ratings. Feedback on speed was provided.

Participants in the immediate choice condition then proceeded directly to the instruction phase. Participants in the unconscious thought condition were confronted with the distractor-task. They saw a set of four objects and had to work for 30 seconds on a 2-back task that required yes/no judgments about whether a digit presented on the computer screen was identical to the digit presented two trials ago. Immediately after the distractor-task the objects had to be rated within 3 seconds. Previous research has shown that the 2-back task effectively blocks working memory and prevents conscious deliberation (cf. Dijksterhuis, 2004). Participants in the conscious thought and conscious thought self-paced conditions saw the same objects but were asked to deliberate for 30 seconds or as long as they wanted, respectively, before they had to rate each object.

During the instruction phase of the experiment, information about the causal system was presented. Participants were told to imagine being a manager of a shoe-company who had to decide which of four shoe-prototypes would go into production. They were asked to base their decision only on the number of stores in which each shoe would be sold in the end. Two retail chains were introduced as relevant for making this decision (see Figure 1). One chain of stores formed a 4-variable common cause structure, in which one superior store caused its three subordinates to sell the same shoes. The other structure was a 4-variable causal chain structure, in which each superior store determined the shoes sold by its direct subordinate. Participants were explicitly told that a store would sell a specific shoe if it had ordered

the shoe itself or its superior store had ordered it. Only the shoe participants picked would be produced, orders of the other three shoes would be obsolete. To ensure that participants understood their task and the causal structures, they had to complete a 7-question multiple-choice test error free. Participants who did not answer all questions correctly had to re-read the instructions. Participants failing the test six times were excluded from later analyses.

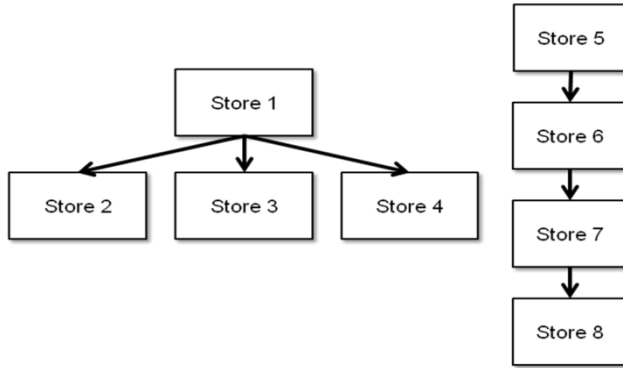

Figure 1: Causal system used in Experiment 1. The common cause sub-structure is shown on the left, the causal chain sub-structure on the right. See text for details.

In the test phase participants were told that they would see which stores had ordered the four prototypes and that they would have to rate each shoe with respect to its sales prospects considering the later dissemination of the shoes within the retail chains. Information about whether a store ordered a specific prototype was presented at the center of the screen for 2.5 seconds. In total 32 pieces of information were presented in trial by trial fashion (4 prototypes x 8 stores). Orders for each prototype were presented in blocks. The sequence of the shoes as well as the sequence of stores within a block was randomized. During the entire test phase participants could not refer back to the instruction or the causal structures.

Figure 2 shows which stores pre-ordered the shoes independently from each other. The four prototypes were ordered by different numbers of stores and had different prospects of being sold at more stores due to their causal relations. Figure 2 shows the implications of the causal structure for the final number of stores. It turns out that Prototype 1, which was ordered by only four stores initially, would be sold by all eight stores, while Prototype 3, which was ordered by six stores, would remain at this level. Prototypes 2 and 4, which were ordered by four and two stores, would be finally sold by four stores, making them the worst choices. Thus, if participants were sensitive to causal structure, they should rate Prototype 1 the best and Prototypes 2 and 4 the worst.

After observing the orders placed by all stores, participants had to rate all four prototypes on an 11-point scale ranging from ‘no store will sell the shoe’ to ‘all stores will sell the shoe’. Depending on the experimental condition the rating task was administered directly after the stimulus pres-

entation (immediate condition), after a 4 minute period of solving a 2-back task (unconscious thought condition), after a 4 minute period of deliberate thinking (conscious thought condition), or whenever the participant felt that he/she had sufficiently thought about the decision (conscious thought self-paced condition). In neither condition the stimuli were visible during the period of (un-)conscious thinking. The order of the shoes to be rated was randomized. If a participant took longer than 3 seconds to complete the rating, a pop-up window reminded him/her to be faster the next time. The experiment ended with a short debriefing.

Orders for Prototypes							
Shoe 1		Shoe 2		Shoe 3		Shoe 4	
S1:y	S5:y	S1:n	S5:y	S1:n	S5:n	S1:y	S5:n
S2:n	S6:y	S2:n	S6:y	S2:y	S6:y	S2:y	S6:n
S3:n	S7:y	S3:n	S7:y	S3:y	S7:y	S3:n	S7:n
S4:n	S8:n	S4:n	S8:y	S4:y	S8:y	S4:n	S8:n
Implied Sales							
S1:y	S5:y	S1:n	S5:y	S1:n	S5:n	S1:y	S5:n
S2:y	S6:y	S2:n	S6:y	S2:y	S6:y	S2:y	S6:n
S3:y	S7:y	S3:n	S7:y	S3:y	S7:y	S3:y	S7:n
S4:y	S8:y	S4:n	S8:y	S4:y	S8:y	S4:y	S8:n

Figure 2: Options to be rated in Exp.1. S1-S8 = Stores, y=order, n = no order

## Results and Discussion

Eighty-eight out of 104 participants passed the knowledge test. One participant was excluded, because his/her ratings differed more than 3 standard deviations from the overall mean. Thus data of 87 participants were considered. All judgments that were made within 5 seconds after the rating scale appeared were included in the analysis. The ratings on the 11-point scale were re-coded to a scale from 0 to 100.

To examine whether participants differentiated between the sales prospects of the different shoes we contrasted the ratings for the best alternative (shoe1) from the mean ratings for the two least preferable alternatives (shoes 2&4) on an individual level (cf. Dijksterhuis, 2004). The mean ratings in the four processing conditions were: Immediate  $M_{S1}=77.2$  ( $SE=4.63$ ),  $M_{S24}=71.4$  ( $SE=4.02$ ), UCT  $M_{S1}=78.8$  ( $SE=3.62$ ),  $M_{S24}=72.9$  ( $SE=3.40$ ), CT  $M_{S1}=77.1$  ( $SE=4.12$ ),  $M_{S24}=66.8$  ( $SE=5.71$ ), CTSP  $M_{S1}=82.8$  ( $SE=4.70$ ),  $M_{S24}=66.7$  ( $SE=4.30$ ). Statistical analyses revealed that these ratings differed significantly only in the conscious thought self-paced condition,  $t(17) = 2.75, p = .014$ . Marginally significant effects resulted in the conscious thought condition,  $t(13) = 2.00, p = .07$ , and the unconscious thought condition,  $t(16) = 1.84, p = .08$ ; no differences were found in the immediate condition,  $t(17) = 1.52, p = .15$  (all tests within

subjects and one-tailed).

In order to test more specifically whether participants were sensitive to the implications of causal structure, we compared ratings for shoe 1 and shoe 3. Shoe 1 is only better if the implications of the causal structure are taken into account, otherwise shoe 3 would be better (cf. Fig. 2). Mean rating of shoe 3 were: Immediate  $M_{S3}=71.5$  ( $SE=4.72$ ), UCT  $M_{S3}=65.3$  ( $SE=5.36$ ), CT  $M_{S3}=65.5$  ( $SE=5.91$ ), CTSP  $M_{S3}=68.2$  ( $SE=5.51$ ). Thus shoe 1 got higher ratings in all conditions. However, differences again turned out to be significant only in the self-paced condition: Immediate  $t(15)<1.18$ ,  $p=.25$ , UCT  $t(11)=1.90$ ,  $p=.083$ , CT  $t(13)=2.13$ ,  $p=.053$ , CTSP  $t(15)=2.26$ ,  $p=.038$  (all tests within subjects and one-tailed).

Taken together, these findings indicate that only participants in the conscious thought self-paced condition were able to take causal structure into account and to differentiate between the normatively best and worst alternatives. Nevertheless, the findings only partially supported our hypotheses. While we expected participants to clearly differentiate between options also in the conscious thought condition, we expected to find a smaller difference in the unconscious thought condition.

## Experiment 2

The purpose of Experiment 2 was to further examine the role of conscious vs. unconscious thought when making decisions with respect to a causal system. While participants in Experiment 1 only had to rate different options, for which the causal system had different implications, they now had to choose between different interventions into the system. In addition, we increased the complexity by using a single causal structure with eight variables connected by eight causal relations.

### Method

**Participants and Design** 87 Göttingen university undergraduates participated for course credit or were paid €7. Participants were again randomly assigned to one of three processing conditions (immediate, unconscious thought, conscious thought).

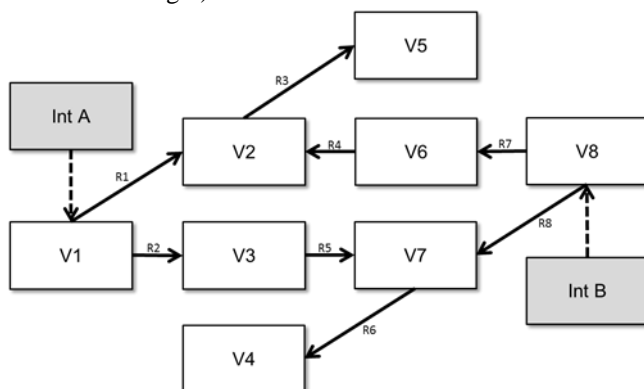

Figure 3: Schematic representation of the causal system used in Exp.2. V1 –V8 = shamanistic techniques or abilities: V1: Knowledge of Gods’ rules; V2: Usage of psychedelic

plants; V3: Skill in using Gods’ language; V4: type of dance; V5: duration of hunger meditation; V6: smoking technique; V7: singing; V8: breathing technique); R1-R8: causal relations (R1: profound (shallow) knowledge leads to adequate (excessive) usage; R2: profound (shallow) knowledge leads to high (low) skill; R3: adequate (excessive) usage leads to long (short) duration; R4: inhaling (whiffing) leads to adequate (excessive) usage; R5: high (low) skill leads to rhythmic (arrhythmic) singing; R6: rhythmic (arrhythmic) singing leads to trance (sun) dance; R7: recapulation (hyperventilation) leads to inhaling (whiffing); R8: recapulation (hyperventilation) leads to rhythmic (arrhythmic) singing); Int A, Int B: possible interventions

**Materials and Procedure** The procedure was very similar to Experiment 1. Participants were first familiarized with the procedure in the test phase. Then they were instructed about the causal system. Figure 3 depicts the causal system used in Experiment 2. Its eight variables were introduced as techniques and abilities of a shaman’s apprentice. The respective technique could either be successful or less successful (see caption of Figure 3 for details). Participants were told that the probability of an apprentice to use a less successful technique/ability was 80%. Some of the techniques/abilities were introduced as causally linked. The usage of a successful technique caused other techniques to become more successful. For example, recapulative breathing (V8), the successful breathing technique, led to inhaling (V7), the more successful smoking technique. Each technique, its successful and less successful version, and the causal relations were explained in detail. The assignment of the abilities/techniques to the model was counterbalanced by mirroring the model depicted in Figure 3.

Participants were told that it was their task to decide which of two trainings should be assigned to an apprentice in order to improve his skills and techniques. One training (Intervention A) made ability V1 successful, while the other training (Intervention B) did the same with technique V8. Participants’ knowledge about the causal system was tested by a 10-item questionnaire. They were required to re-read the instruction if they made any errors. Participants who failed the test six times were excluded from later analyses.

The following test phase consisted of 8 trials in randomized order. On each trial the eight techniques/abilities of a single apprentice were presented separately for 1.5 seconds each in random order. Figure 4 shows the techniques/abilities of the apprentices serving as the eight test cases. Note that in all cases both fundamental techniques/abilities (V1 and V8) were not successful, which entails that both trainings would have some effect. Four of the cases favored no specific intervention and served as a baseline for analysis. The remaining cases had clear-cut best interventions that could be figured out by considering the structure and state of the causal system. For example, in Case 2 Intervention A would only change V1 for the better as V1’s causally dependent techniques were already successful. Intervention B, by contrast, would not only improve

V8 but also V6, V7, and V4, which would be causally affected by V8 becoming successful.

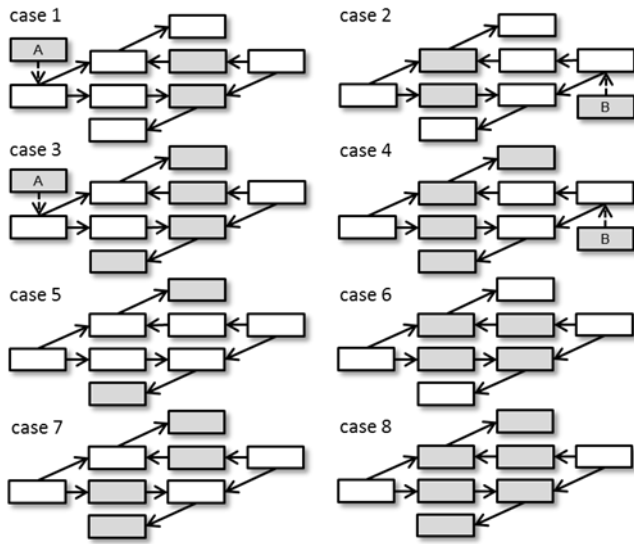

Figure 4: Cases to be judged in Exp. 2. Gray fillings indicate successful techniques/abilities, white fillings less successful techniques/abilities. The more effective intervention (A/B) is marked when applicable.

After the presentation of each test case, participants had to judge whether Intervention A or B was preferable. As in Experiment 1, participants could not refer back to the instruction or the causal model when making their judgment. The judgment was made on an 11-point rating scale with the two possible interventions as endpoints (the endpoints of the scale were counterbalanced across participants). In the immediate condition participants were asked to indicate their preference directly after observing each apprentice. In the unconscious thought condition they worked on a two-back task for 2 minutes and in the conscious thought condition they deliberated about the best option for the same amount of time before making a decision. Participants had 3 seconds to indicate their answer. They were reminded to be faster next time if they took longer. No feedback was provided. The experiment ended with a short debriefing.

## Results and Discussion

Eighty-one out of eighty-seven participants passed the knowledge test. One participant was excluded, because he/she did not provide any answers to the cases having differential implications for choice within the given time window. Thus data of 80 participants were considered. Participants' ratings on the 11 point scale were coded on a scale from 0 (Intervention A) to 100 (Intervention B). All judgments that were made within 5 seconds after the rating scale appeared were included in the analysis. To facilitate further analyses, participants' ratings of cases that favored Intervention A, Intervention B, or no specific intervention were aggregated on an individual level. Figure 5 depicts the mean ratings for the three types of cases in the three experimental

conditions. As can be seen from Figure 5, different ratings resulted across conditions. Participants tended to favor the specific intervention for the respective cases, and tended to be indifferent for the rest. However, the differences between cases seemed to be most pronounced in the conscious thought condition.

For the statistical analyses we compared the mean ratings for the cases affording a specific intervention with the mean rating of the cases, for which both interventions would be equally effective (indifferent cases). We conducted two-sided t-tests with a Bonferroni-corrected significance level of  $\alpha = .025$ . In the immediate condition there was a significant difference between cases favoring Intervention A and the indifferent cases ( $t(30) = 3.18, p < .01$ ) whereas the difference between cases favoring Intervention B and the indifferent cases was not significant ( $t(30) = 1.75, p = .08$ ). In the unconscious thought condition, the comparisons did not reveal any significant differences: Intervention A vs. Indifferent  $t(25) = 1.07, p = .29$  and Intervention B vs. Indifferent  $t(25) = 2.16, p = .04$ . By contrast, both comparisons turned out significant in the conscious thought condition: Intervention A vs. Indifferent  $t(22) = 2.83, p < .01$  and Intervention B vs. Indifferent  $t(22) = 6.05, p < .01$ . This pattern of results indicates that deliberation improves decision making with respect to interventions in a causal system.

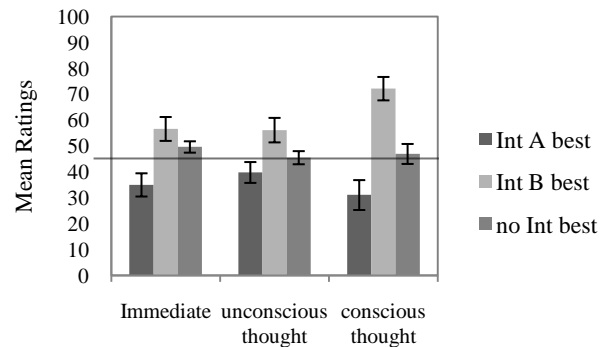

Figure 5: Mean ratings for cases entailing that Intervention A would be best (Int A best), cases for which Intervention B would be best (Int B best) and cases for which both interventions would be equally effective (no Int best) in the three processing conditions. Error bars indicate standard errors.

However, one may argue that the above tests are too strict. In fact, the differences between ratings of cases that asked for Intervention A and those that afforded Intervention B were significant in all three conditions: Immediate  $t(30) = 2.76, p < .01$ ; unconscious thought  $t(25) = 2.84, p < .01$ ; conscious thought  $t(22) = 5.14, p < .01$ . To further analyze whether conscious deliberation did lead to superior results, we tested whether the differences between the cases favoring specific interventions differed across conditions. The differences of the differences did not approach significance when the immediate and the unconscious thought condition were compared ( $t(55) = 0.52, p = .6$ ). But, the difference in the conscious thought condition was significantly larger

than the differences in the immediate thought condition ( $t(52) = 2.03, p < .05$ ) and the unconscious thought condition ( $t(47) = 2.82, p < .01$ ). These results clearly indicate that participants in the conscious thought condition were more sensitive for the causal effects of the interventions than in the other conditions.

Taken together, the results obtained in Experiment 2 provide further evidence for the claim that conscious deliberation enhances performance if a consideration of causal structure is required to make appropriate decisions. Thus the findings support our hypothesis. Interestingly, the results in the other conditions indicate some sensitivity for causal structure, whose origin may be due to some form of causal reasoning during information acquisition.

### General Discussion

The goal of the current set of experiments was to investigate how unconscious thought and conscious deliberation affect decision making with respect to a causal system. Both experiments used an experimental procedure introduced by Dijksterhuis (2004) that forces participants to make their decision either immediately after receiving the relevant information, after a period of distraction from the task, or after a period of deliberate thinking about the task. Going beyond previous studies, we asked participants to evaluate options having different causal effects (Experiment 1) or to choose between interventions having differential consequences (Experiment 2). The results of both experiments demonstrated that a period of conscious deliberation led to better decisions than unconscious thought.

These findings are at odds with Unconscious Thought Theory (UTT, Dijksterhuis & Nordgren, 2006), which assumes that the unconscious processing of decision relevant information leads to better decisions. However, UTT has only been applied to decisions requiring the weighting and integration of multiple pieces of information. Decisions which pertain to a causal system require more. They require considering the causal consequences resulting from the choice made (cf. Sloman & Haggmayer, 2006). To make these inferences, causal reasoning seems to be necessary, which takes into account the structure and state of the underlying causal system. Causal reasoning has been assigned to System 2, the deliberate, rule based system of reasoning (Sloman, 1996, Evans 2008). Therefore our results are in line with causal model theories of decision making, which assume that causal reasoning is involved when decisions are made with respect to a causal system. Decision makers seem to need some time to build up a causal model representation and to figure out the causal consequences resulting from the given options. This is probably why extra time for deliberation improves these kinds of decisions.

Although our findings were at odds with UTT, we believe that they do not contradict this theory. They rather point out UTT's limits. Several studies in different domains showed that unconscious thought may lead to better decisions than conscious thought (cf. Dijksterhuis et al., 2006; see Newell et al., 2009, for contradictory findings). Unconscious

thought seems to have an advantage if a large amount of information has to be integrated, holistic judgments are required, or recurring patterns have to be detected (Dijksterhuis & Nordgren, 2006). Decision making with respect to a causal system, however, seems to be beyond the scope of UTT.

### Acknowledgments

This research was supported by a grant of the Deutsche Forschungsgemeinschaft (DFG HA 3406/3-1).

### References

- Dijksterhuis, A., & Nordgren, L. F. (2006). A Theory of Unconscious Thought. *Perspectives on Psychological Science, 1*, 95-109.
- Dijksterhuis, A., Bos, M. W., Nordgren, L. F., & van Baaren, R. B. (2006). On making the right choice: The deliberation-without-attention effect, *Science, 311*, 1005-1007.
- Dijksterhuis, A. (2004). Think different: The merits of unconscious thought in preference development and decision making. *Journal of Personality and Social Psychology, 87*, 286-598.
- Evans, J. S. B. T. (2008). Dual-processing accounts of reasoning, judgment, and social cognition, *The Annual Review of Psychology, 59*, 255-278.
- Haggmayer, Y., Meder, B., Osman, M., Mangold, S., & Lagnado, D. (2010). Spontaneous causal learning while controlling a dynamic system. *The Open Psychology Journal, 3*, 145-162.
- Haggmayer, Y., & Sloman, S. (2009). People conceive of their choices as intervention. *Journal of Experimental Psychology: General, 138*, 22-38.
- Klein, G. A. (1998). *Sources of power: How people make decisions*. Cambridge, MA: MIT Press.
- Lerouge, D. (2009). Evaluating the benefits of distraction on product evaluations: The mind-set effect, *Journal of Consumer Research, 36*, 367-379.
- Newell, B. R., Wong, K. Y., Cheung, J. C. H., & Rakow, T. (2009). Think, blink or sleep on it? The impact of modes of thought on complex decision making, *The Quarterly Journal of Experimental Psychology, 62*, 707-732.
- Payne, J. W., Samper, A., Bettman, J. R., Luce, M. F. (2008). Boundary conditions on unconscious thought in complex decision making, *Psychological Science, 19*, 1118-1123.
- Sloman, S. A., & Haggmayer, Y. (2006). The causal psychology of choice. *Trends in Cognitive Science, 10*, 407-412.
- Sloman, S. A. (2005). *Causal models*. Cambridge, MA: Oxford University Press.
- Sloman, S. A. (1996). The empirical case for two systems of reasoning, *Psychological Bulletin, 119*, 3-22.
- Strick, Dijksterhuis, & van Baaren (2010). Unconscious thought effects take place off-line, not on-line, *Psychological Science, 21*, 484-488.